



High speed precision spindles

# SCHEDA TECNICA KNS 21 SCF



MODELLO	TENSIONE [Volt]	FREQUENZA [Hz]	GIRI	POT. RESA [Kw]	ASSORB. [Amp]	Cos j	PESO [Kg]
KNS21 6/2	220/380	100	6000	0,09	0,70/0,40	0,65	1,8
KNS21 6/2	220/380	200	12000	0,16	1,10/0,64	0,70	1,8
KNS21 6/2	220/380	300	18000	0,22	1,73/1,00	0,70	1,8
KNS21 7/2	220/380	100	6000	0,11	0,85/0,49	0,65	2
KNS21 7/2	220/380	200	12000	0,22	1,50/0,85	0,70	2
KNS21 7/2	220/380	300	18000	0,33	2,10/1,20	0,70	2
KNS21 8.5/2	220/380	100	6000	0,22	1,50/0,86	0,65	2,5
KNS21 8.5/2	220/380	200	12000	0,37	2,30/1,30	0,70	2,5
KNS21 8.5/2	220/380	300	18000	0,55	3,20/1,85	0,70	2,5

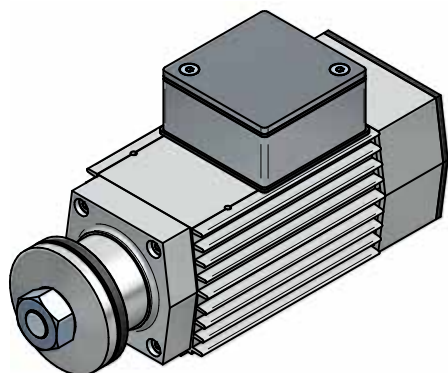
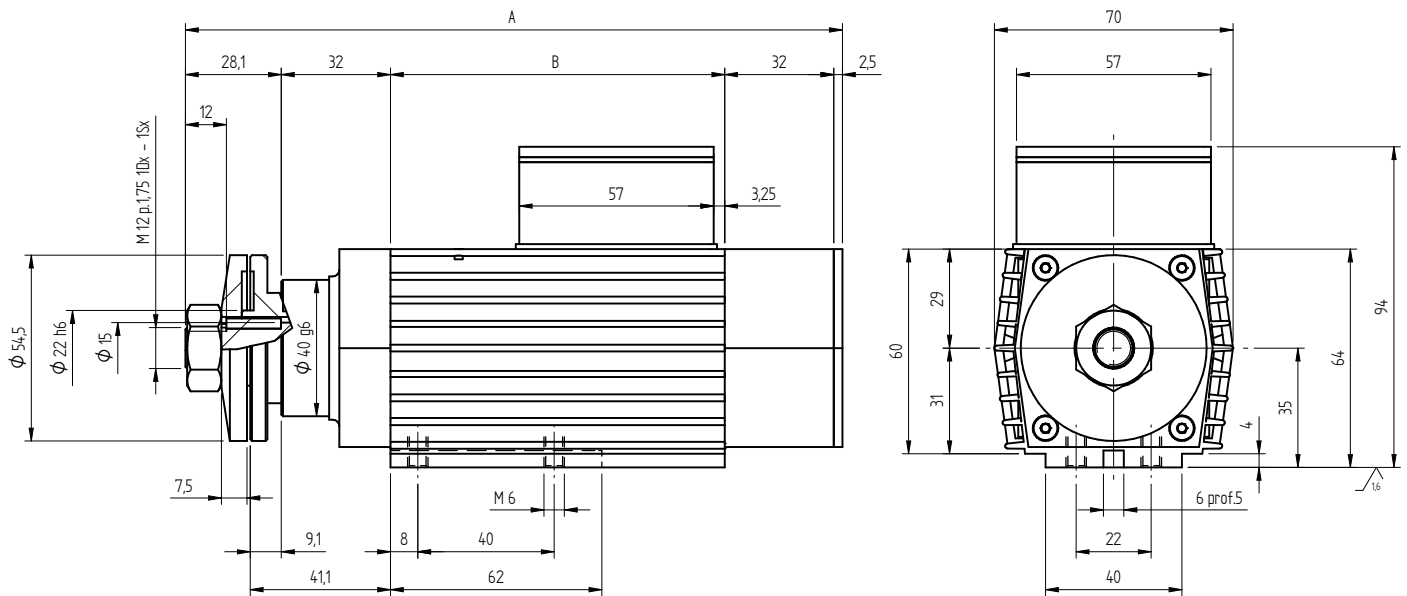

TIPO	A	B
KNS 21 6/2	192,5	98
KNS 21 7/2	192,5	98
KNS 21 8,5/2	227,5	133

