



High speed precision spindles

SCHEDA TECNICA

PE O SL



MODELLO	TENSIONE [Volt]	FREQUENZA [Hz]	GIRI	POT. RESA [Kw]	ASSORB. [Amp]	Cos j	PESO [Kg]
PEO 3.5/2	220/380	200	12000	0,08	0,60/0,34	0,65	1,2
PEO 3.5/2	220/380	300	18000	0,12	0,78/0,45	0,69	1,2
PEO 6/2	220/380	100	6000	0,05	0,45/0,26	0,61	1,5
PEO 6/2	220/380	200	12000	0,15	0,80/0,45	0,68	1,5
PEO 6/2	220/380	300	18000	0,30	1,70/1,00	0,70	1,5
PEO 8/2	220/380	100	6000	0,07	0,55/0,32	0,61	1,8
PEO 8/2	220/380	200	12000	0,18	1,20/0,69	0,64	1,8
PEO 8/2	220/380	300	18000	0,35	1,70/1,00	0,70	1,8

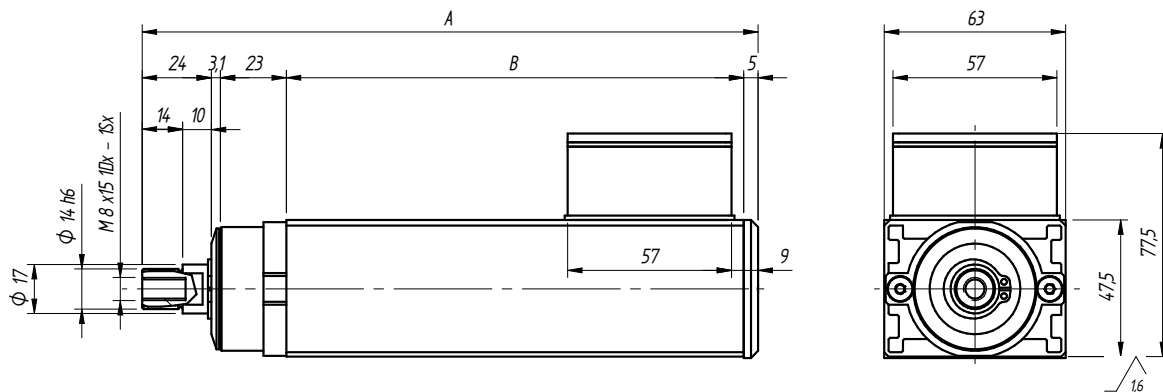
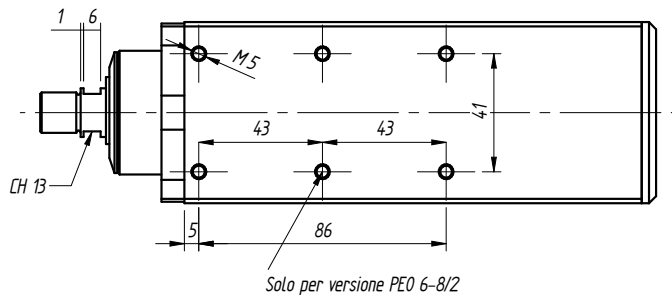

TIPO	A	B
PEO 3.5/2	174	119
PEO 6/2	199	144
PEO 8/2	214	159

