



High speed precision spindles

SCHEDA TECNICA TMPE 3 SC S



MODELLO	TENSIONE [Volt]	FREQUENZA [Hz]	GIRI	POT. RESA [Kw]	ASSORB. [Amp]	Cos j	PESO [Kg]
TMPE3 9/2	220/380	50	3000	0,20	1,50/0,90	0,70	7,2
TMPE3 9/2	220/380	100	6000	0,45	2,40/1,40	0,75	7,2
TMPE3 9/2	220/380	200	12000	0,75	4,00/2,30	0,75	7,2
TMPE3 9/2	220/380	300	18000	1,00	5,50/3,20	0,75	7,2
TMPE3 9/2	220/380	400	24000	1,00	5,50/3,20	0,75	7,2
TMPE3 12/2	220/380	50	3000	0,30	1,70/1,00	0,70	8,2
TMPE3 12/2	220/380	100	6000	0,75	3,30/1,90	0,75	8,2
TMPE3 12/2	220/380	200	12000	1,50	6,30/3,60	0,79	8,2
TMPE3 12/2	220/380	300	18000	2,00	9,00/5,20	0,80	8,2
TMPE3 12/2	220/380	400	24000	2,20	9,50/5,50	0,80	8,2

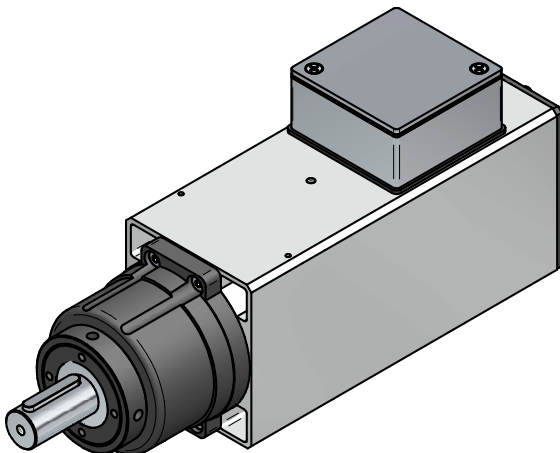
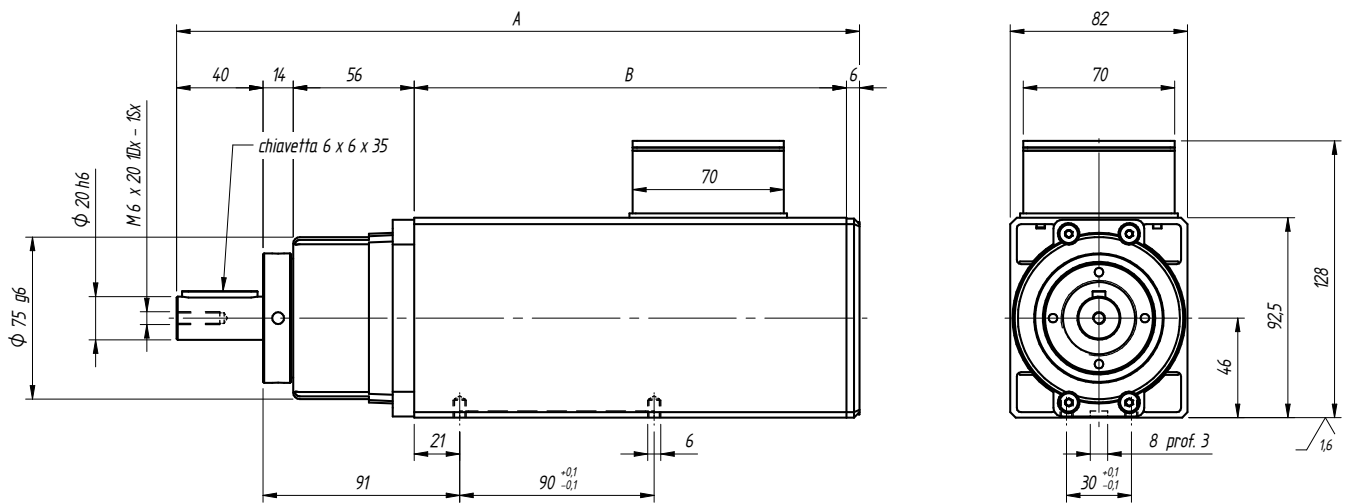

TIPO	A	B
TM PE3 9/2	316	200
TM PE3 12/2	356	240

