



High speed precision spindles

SCHEDA TECNICA

TMPE5 HSK A50 L



MODELLO	TENSIONE [Volt]	FREQUENZA [Hz]	GIRI	POT. RESA [Kw]	ASSORB. [Amp]	Cos j	PESO [Kg]
TMPE5 10/2	220/380	50	3000	1,25	5,60/3,20	0,78	12
TMPE5 10/2	220/380	100	6000	1,90	7,55/4,35	0,83	12
TMPE5 10/2	220/380	200	12000	3,0	12,30/7,10	0,80	12
TMPE5 10/2	220/380	250	15000	3,60	14,30/8,20	0,81	12
TMPE5 14/2	220/380	50	3000	3,0	11,50/6,60	0,82	19,5
TMPE5 14/2	220/380	100	6000	4,0	15,20/8,80	0,82	19,5
TMPE5 14/2	220/380	200	12000	4,50	18,20/10,60	0,85	19,5
TMPE5 14/2	220/380	250	15000	6,0	21,70/12,50	0,86	19,5

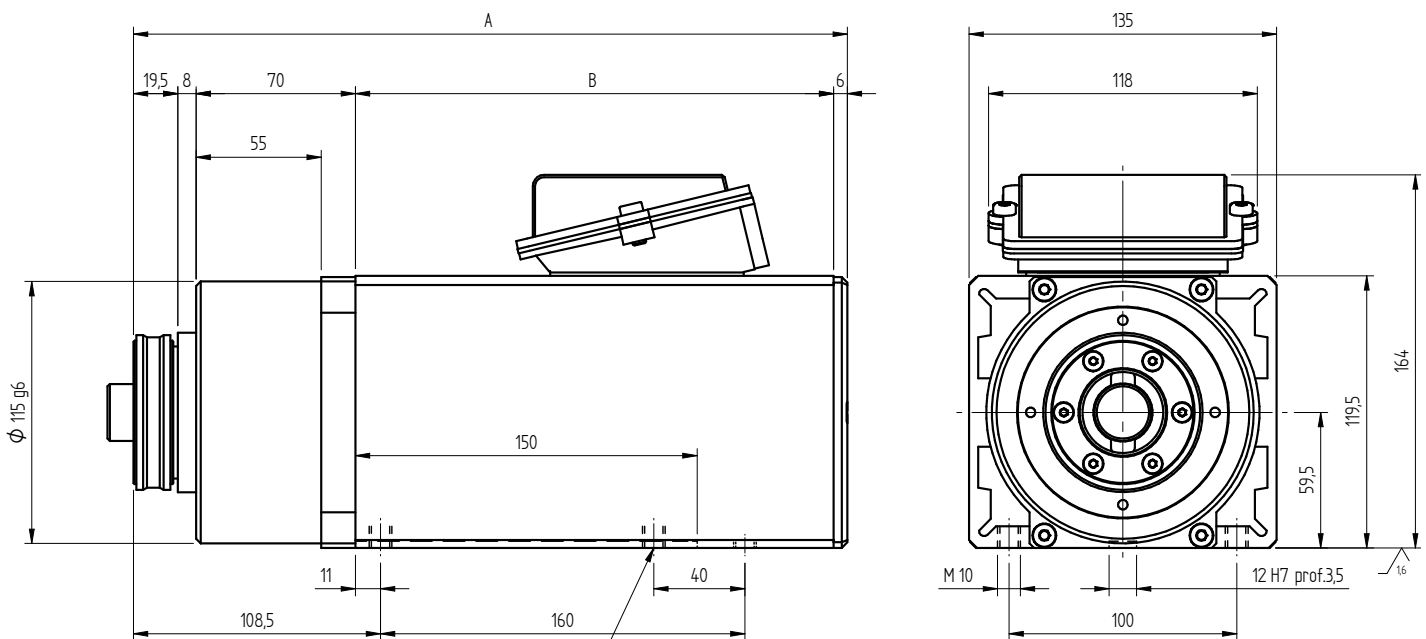

n°2 fori solo per versione 10/2

ECCENTRICITA' MAX ALLA FINE DEL PORTAPINZA 0,02 mm

TIPO	A	B
TM PE5 10/2	313,5	210
TM PE5 14/2	353,5	250

