

CARTRIDGE SPINDLE LINE



CARTRIDGE SPINDLE LINE

Mandrino a cartuccia per la fresatura del marmo, granito e vetro con passaggio del refrigerante lungo l'asse. È realizzato totalmente in inox, ideale contro la corrosione. Velocità massima dell'elettromandrino ottenuta con cuscinetti lubrificati a grasso.

CARTRIDGE SPINDLE LINE

Cartridge spindle for steel marble, granite and glass milling. It is equipped with encoder and cooling system through the shaft. All exposed parts are built with corrosion resistant alloys. The maximum speed is achieved with grease lubrication.

CARTRIDGE SPINDLE LINE

Zylindrische Elektroschleifspindel für die Fräsbearbeitung von Marmor, Granit, Glass mit Geschwindigkeitsrückführung, Sperrsystem und Achsenkühlung. Alle Teile sind von Korrosion geschützt. Die maximale Drehzahl wird durch Kugellager mit Fettschmierung erreicht.

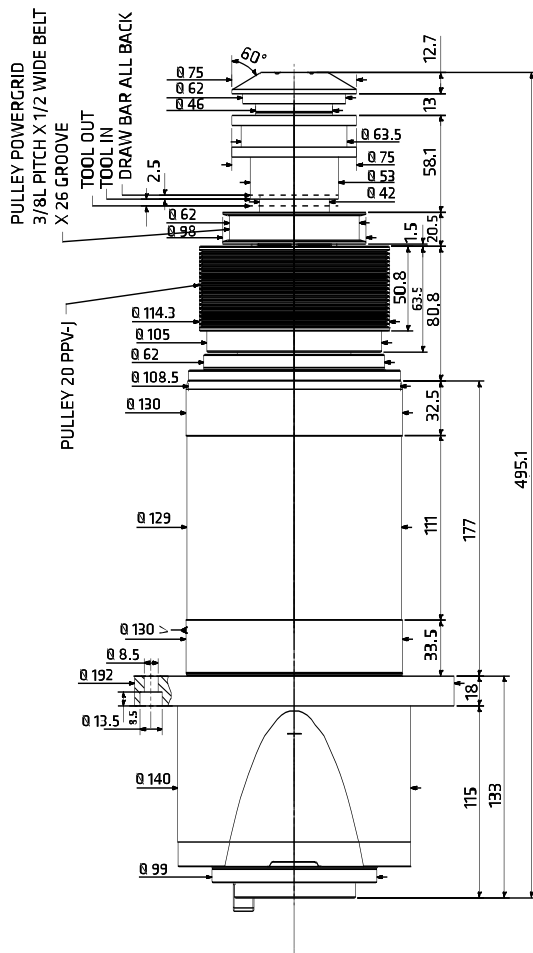
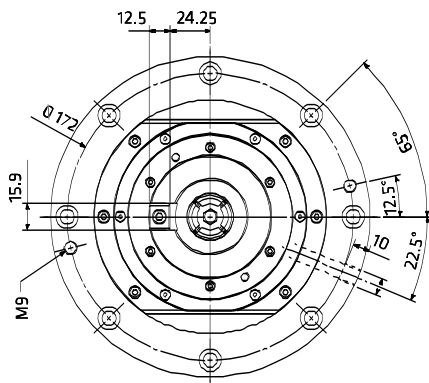

Tipo Elettromandrino Type of Electrosindle Elektrospindeltyp	CARTRIDGE SPINDLE LINE
Velocità massima $n(\text{min}^{-1})$ Spin speed max $n(\text{min}^{-1})$ Max. Drehzahl $n(\text{min}^{-1})$	10000
Attacco utensile Holder Werkzeugaufnahme	ISO 40