

HiL 130 FC

SHORT NOSE - LONG NOSE



HiL 130 FC

(cambio utensile automatico)

Fresatura e foratura di pannelli in massello e profilati in alluminio, incisione di bassorilievi e targhe.

HiL 130 FC

(automatic tool change)

Milling and drilling of solid wood panels or aluminium profiles. Plates and bas-reliefs engraving.

HiL 130 FC

(automatischer Werkzeugwechsel)

Fräsen und Bearbeitung von ausgepresstem Aluminium oder Kernholztafeln. Einfräsungen von Flachreliefs und Schildern.

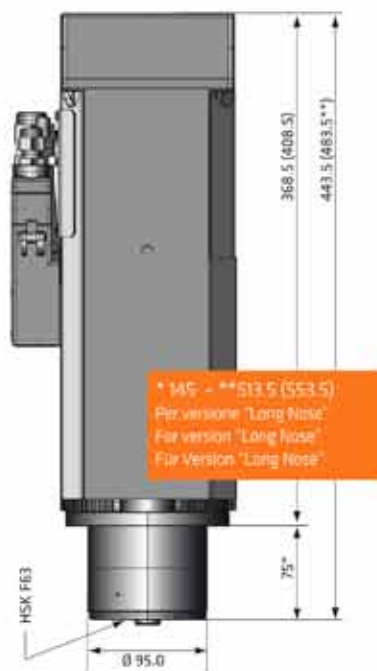
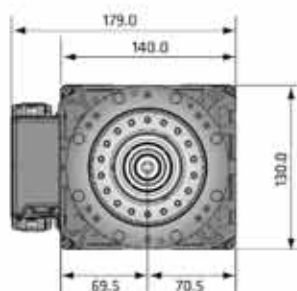

I dati tra parentesi sono relativi alla versione 8,5 kW
All data between parenthesis are relative to 8.5 kW version
Die in Klammern stehenden Daten beziehen sich auf das Modell mit 8.5 kW Leistung

Potenza Power Leistung

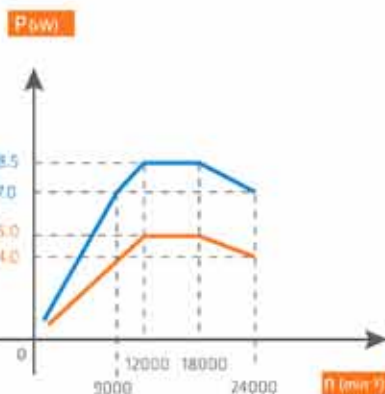

Coppia Moment Torque Drehmoment

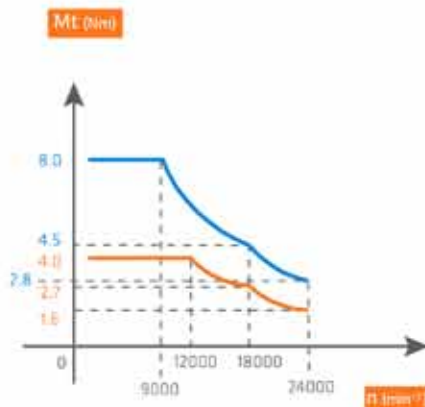

Disponibile nelle versioni "naso corto" e "naso lungo"
Available in versions "short nose" and "long nose"
Verfügbar in den Versionen "short nose" und "long nose"

Tipo Elettromandrino Type of Electrospindle Elektrospindeltyp	HiL 130 FC
Potenza (kW) Power (kW) Leistung	5/8,5
Coppia (Nm) Torque (Nm) Drehmoment (Nm)	4/8
Velocità massima n(min-1) Cuscinetti ceramici Max speed n(min-1) Hybrid ball bearings Max Drehzahl n(min-1) Kegellager mit Keramikugeln	24000
Attacco utensile Tool Taper Werkzeugaufnahme	HSK F 63
Raffreddamento motore Motor Cooling Motorkühlung	Elettroventola Fan Cooled Fan Cooled