

COMPACT 115 LC

SHORT NOSE



COMPACT 115 LC

(cambio utensile automatico)

Per la fresatura ad alta velocità dei modelli in resina o alluminio, lavorazione su acetati, fresature e finitura di stampi e punzoni.

COMPACT 115 LC

(automatic tool change)

High-speed milling of resin or aluminium moulds, acetate plastic shaping, milling and finishing of die-cast.

COMPACT 115 LC

(automatischer Werkzeugwechsel)

Hochgeschwindigkeitsfräsen für Kunststoff- und Aluminiummodelle, Bearbeitung von Acetaten, Fräsen bzw. Fertigbearbeitung von Modellen und Stempeln.

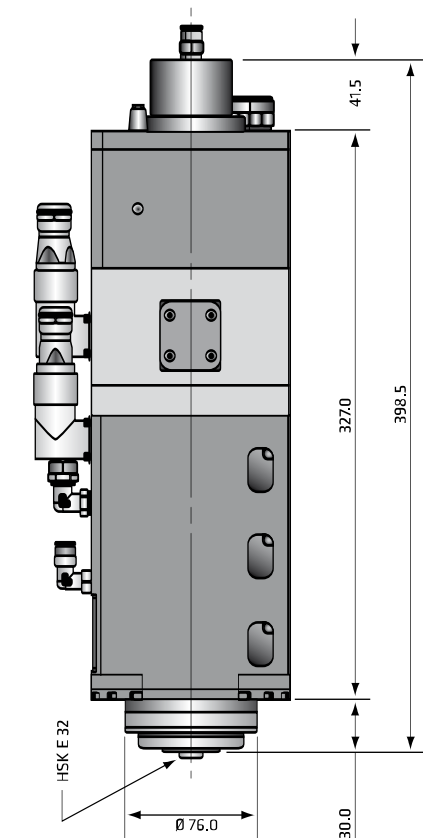
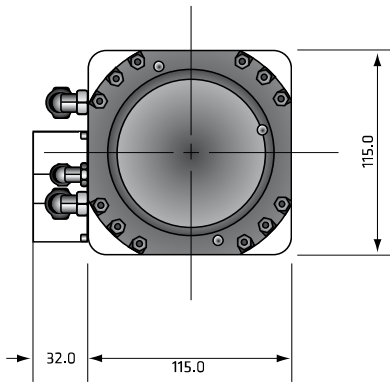

Potenza Power Leistung

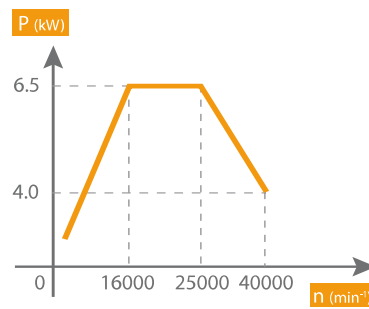

Coppia Torque Drehmoment

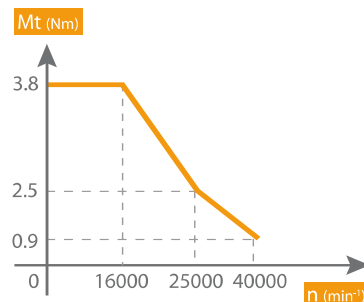

Tipo Elettromandrino Type of Electros spindle Elektrospindeltyp	Compact 115 LC
Potenza (kW) Power (kW) Leistung	6,5
Coppia (Nm) Torque (Nm) Drehmoment (Nm)	3,8
Velocità massima n (min ⁻¹) Cuscinetti ceramici Max speed n (min ⁻¹) Hybrid ball bearings	32000
Max Drehzahl n (min ⁻¹) Kegellager mit Keramikugeln	
Velocità massima n (min ⁻¹) Cuscinetti in Cronidur Max speed n (min ⁻¹) Cronidur ball bearings	40000
Max Drehzahl n (min ⁻¹) Cronidur-Kugellager	
Attacco utensile Tool Taper Werkzeugaufnahme	HSK E 32
Raffreddamento motore Motor Cooling Motorkühlung	Liquido Liquid Flüssig