

ELETTROMANDRINI DA TAGLIO / ELECTROSPINDLES FOR CUTTING OPERATIONS



Taglio con disco
Disc cutting



Inserto "Easyspin" su taglie 93 e 107
"Easyspin" insert on size 93 and 107



Classe di protezione IP66
IP66 degree of protection



Morsetteria disponibile in 8 posizioni
Terminal box available in 8 positions



Raffreddamento ad aria
Air cooled



SBE PLATFORM COMPATIBLE
SBE PLATFORM COMPATIBLE

DISCOVER THE NEW M.O.D.E.

MODULARITA'
MODULARITY



OTTIMIZZAZIONE
OPTIMIZATION



DESIGN
DESIGN



EVOLUZIONE
EVOLUTION



SBE

www.saccardo.it

MADE IN ITALY



SBE 76

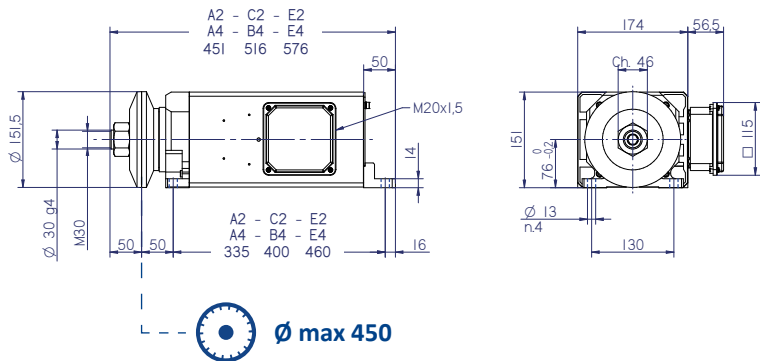

2 POLES / 400V

Size	Duty	50 Hz				Kg
		kW	Nm	rpm	A	
A2	S1	2,6	8,7	2840	5,8	30
	S6-60%	3,1	10,5	2825	7	
C2	S1	4,2	14,1	2855	9,3	36
	S6-60%	4,9	16,5	2840	11,1	
E2	S1	5	16,7	2865	10,9	43
	S6-60%	5,9	19,8	2850	12,9	

Max vel. 4500 rpm (75 Hz)
Max speed 4500 rpm (75 Hz)

4 POLES / 400V

Size	Duty	50 Hz				Kg
		kW	Nm	rpm	A	
A4	S1	2,2	15,1	1390	5,6	32
	S6-60%	2,6	18,1	1370	6,7	
B4	S1	3,1	21,1	1405	8	36
	S6-60%	3,7	25,5	1385	9,5	
E4	S1	4,7	32	1405	10,6	42
	S6-60%	5,5	37,8	1390	12,4	

Max vel. 4500 rpm (150 Hz)
Max speed 4500 rpm (150 Hz)

SBE 93

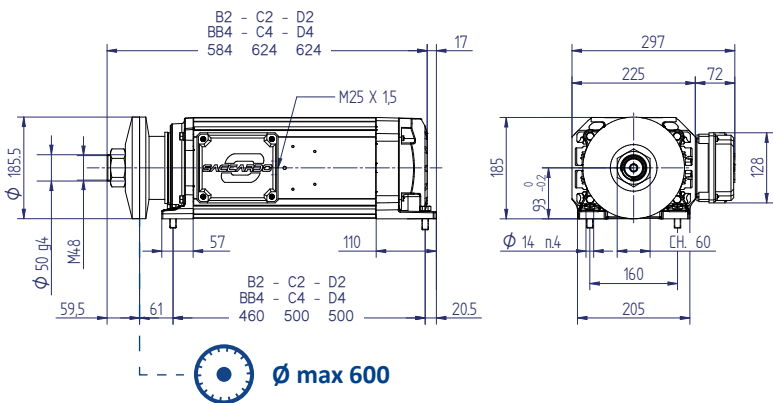

2 POLES / 400V

Size	Duty	50 Hz				Kg
		kW	Nm	rpm	A	
B2	S1	8	26	2880	17	69
	S6-60%	9,5	32	2860	20,3	
C2	S1	10	33	2890	21,2	65
	S6-60%	11,8	39	2870	25	
D2	S1	11,2	37	2900	23,6	71
	S6-60%	12,5	41	2880	26,8	

Max vel. 4500 rpm (75 Hz)
Max speed 4500 rpm (75 Hz)

4 POLES / 400V

Size	Duty	50 Hz				Kg
		kW	Nm	rpm	A	
BB4	S1	6,3	42	1425	13,7	56
	S6-60%	7,5	51	1405	16,5	
C4	S1	9	60	1425	19	63
	S6-60%	11	75	1405	23,5	
D4	S1	10	67	1425	21,2	71
	S6-60%	11,8	80	1405	25	

Max vel. 4500 rpm (150 Hz)
Max speed 4500 rpm (150 Hz)

SBE.S 93

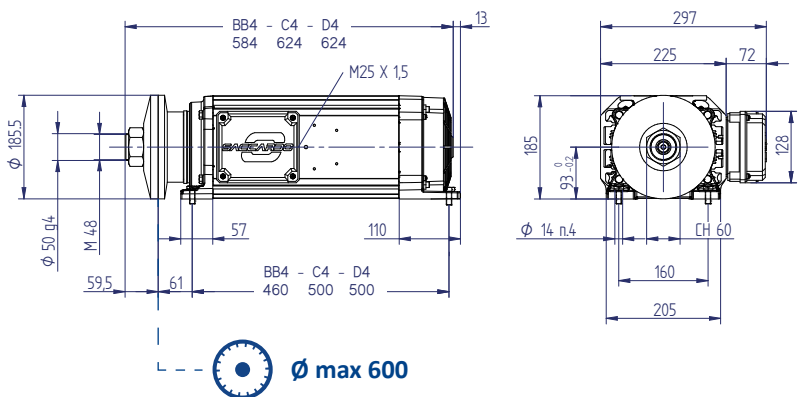

Servoventilato 24 Volt DC
Servo-fan 24 Volt DC

Rumorosità < 80dB
Noise < 80dB



4 POLES / 400V

Size	Duty	50 Hz				Kg
		kW	Nm	rpm	A	
BB4	S1	7	47	1415	15,2	56
	S6-60%	8,3	57	1395	18,3	
C4	S1	9,8	66	1415	20,4	63
	S6-60%	12	82	1395	25,3	
D4	S1	11	74	1415	23,3	71
	S6-60%	13	89	1395	27,5	

Max vel. 4500 rpm (150 Hz)
Max speed 4500 rpm (150 Hz)

SBE 107

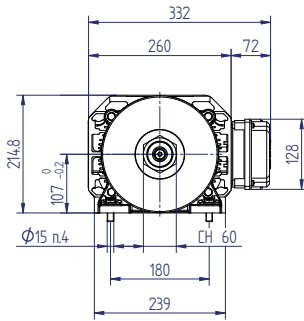
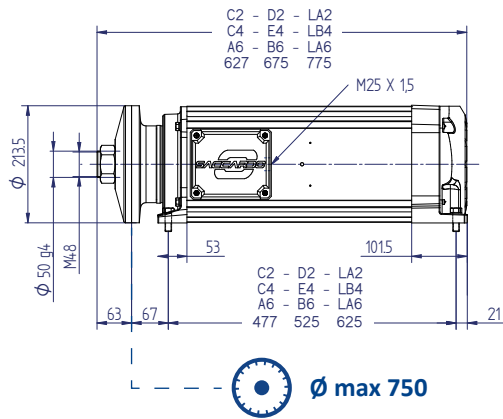

2 POLES / 400V

Size	Duty	50 Hz					Kg
		kW	Nm	rpm	A		
C2	S1	15	50	2890	28,2	84	
	S6-60%	18	60	2865	33,5		
D2	S1	18	59	2890	33,8	95	
	S6-60%	21,2	71	2870	39,3		
LA2	S1	22	72	2900	41,6	103	
	S6-60%	26,5	88	2870	49,2		

Max vel. 4500 rpm (75 Hz)
 Max speed 4500 rpm (75 Hz)

4 POLES / 400V

Size	Duty	50 Hz					Kg
		kW	Nm	rpm	A		
C4	S1	11	73	1430	24,2	87	
	S6-60%	13	88	1410	28,5		
E4	S1	14,6	97	1430	30	99	
	S6-60%	16,5	111	1420	36,8		
LB4	S1	20	133	1435	43	129	
	S6-60%	23,5	158	1420	48,5		

Max vel. 4500 rpm (150 Hz)
 Max speed 4500 rpm (150 Hz)

6 POLES / 400V

Size	Duty	50 Hz					Kg
		kW	Nm	rpm	A		
A6	S1	5,6	56	950	13,2	77	
	S6-60%	6,5	66	942	14,7		
B6	S1	8,5	86	945	18,5	98	
	S6-60%	10	102	935	21,3		
LA6	S1	11,8	119	945	25,3	128	
	S6-60%	13,5	137	940	28,5		

Max vel. 4500 rpm (225 Hz)
 Max speed 4500 rpm (225Hz)

SBE.S 107

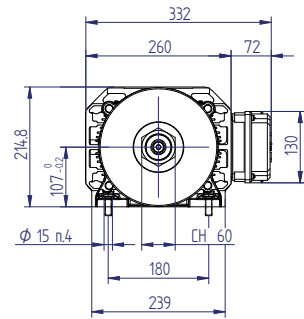
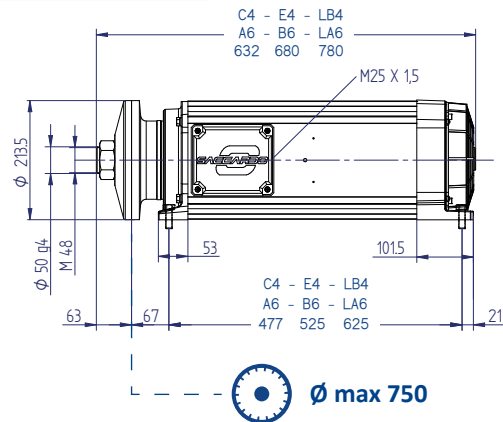

Servoventilato 24 Volt DC
Servo-fan 24 Volt DC

Rumorosità < 80dB
Noise < 80dB

4 POLES / 400V

Size	Duty	50 Hz					Kg
		kW	Nm	rpm	A		
C4	S1	13	86	1440	28	87	
	S6-60%	15,4	105	1420	31		
E4	S1	16	113	1435	36	99	
	S6-60%	19,2	128	1420	40		
LB4	S1	22	147	1430	45	129	
	S6-60%	25,9	175	1415	52		

Max vel. 4500 rpm (150 Hz)
 Max speed 4500 rpm (150 Hz)

6 POLES / 400V

Size	Duty	50 Hz					Kg
		kW	Nm	rpm	A		
A6	S1	7	71	945	16,3	78	
	S6-60%	8,1	83	930	18,3		
B6	S1	10	101	945	22,4	98	
	S6-60%	11,8	120	930	25,8		
LA6	S1	14	141	950	31,8	128	
	S6-60%	16	162	940	34,8		

Max vel. 4500 rpm (225 Hz)
 Max speed 4500 rpm (225Hz)

SBE.L 107

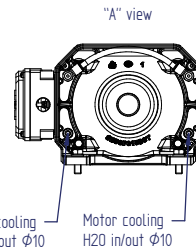
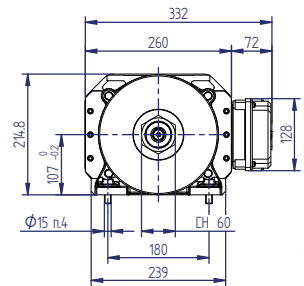
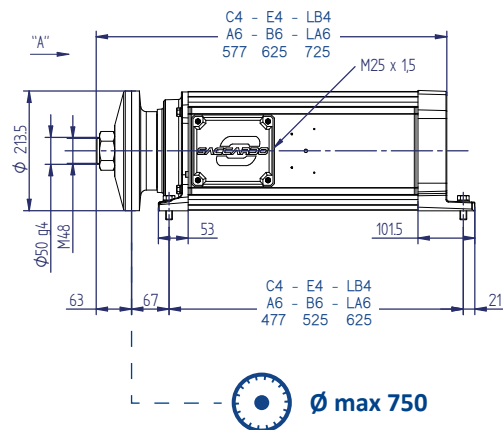

Rumorosità < 80dB
Noise < 80dB

Raffreddato a liquido
Liquid cooling

4 POLES / 400V

Size	Duty	50 Hz					Kg
		kW	Nm	rpm	A		
C4	S1	16	107	1425	32	89	
	S6-60%	19,2	130	1405	39		
E4	S1	22	148	1415	45	100	
	S6-60%	25,9	177	1395	53		
LB4	S1	27	181	1425	55	130	
	S6-60%	33,2	226	1405	67		

Max vel. 4500 rpm (150 Hz)
 Max speed 4500 rpm (150 Hz)

6 POLES / 400V

Size	Duty	50 Hz					Kg
		kW	Nm	rpm	A		
A6	S1	10	102	935	25	79	
	S6-60%	11,8	122	920	28,5		
B6	S1	14	143	935	32,4	99	
	S6-60%	16	165	925	36,2		
LA6	S1	18,5	189	935	41,7	129	
	S6-60%	22	228	920	48,1		

Max vel. 4500 rpm (225 Hz)
 Max speed 4500 rpm (225 Hz)

SBE 127

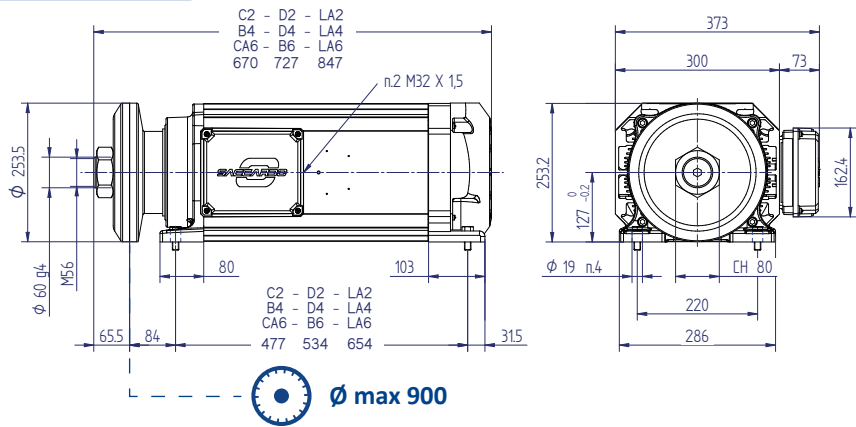

2 POLES / 400V

Size	Duty	50 Hz				Kg
		kW	Nm	rpm	A	
C2	S1	28	92	2900	51,5	145
	S6-60%	33	110	2865	61	
D2	S1	30	99	2900	55,5	150
	S6-60%	36	120	2870	65	
LA2	S1	35,5	117	2900	65	159
	S6-60%	42,5	141	2870	77	

Max vel. 3800rpm (63 Hz)
 Max speed 3800 rpm (63 Hz)

4 POLES / 400V

Size	Duty	50 Hz				Kg
		kW	Nm	rpm	A	
B4	S1	20	132	1445	42,1	134
	S6-60%	23	155	1420	49,5	
D4	S1	24	157	1455	53	148
	S6-60%	29,5	197	1430	61,5	
LA4	S1	30	197	1455	67	169
	S6-60%	37,5	250	1430	78	

Max vel. 3800rpm (127 Hz)
 Max speed 3800 rpm (127 Hz)

6 POLES / 400V

Size	Duty	50 Hz				Kg
		kW	Nm	rpm	A	
CA6	S1	14,6	145	960	29,5	123
	S6-60%	17,5	177	945	38,5	
B6	S1	18	178	965	40	143
	S6-60%	21,5	216	950	46,5	
LA6	S1	24	237	965	53	169
	S6-60%	28,5	286	950	61	

Max vel. 3800rpm (190 Hz)
 Max speed 3800 rpm (190 Hz)

SBE.S 127

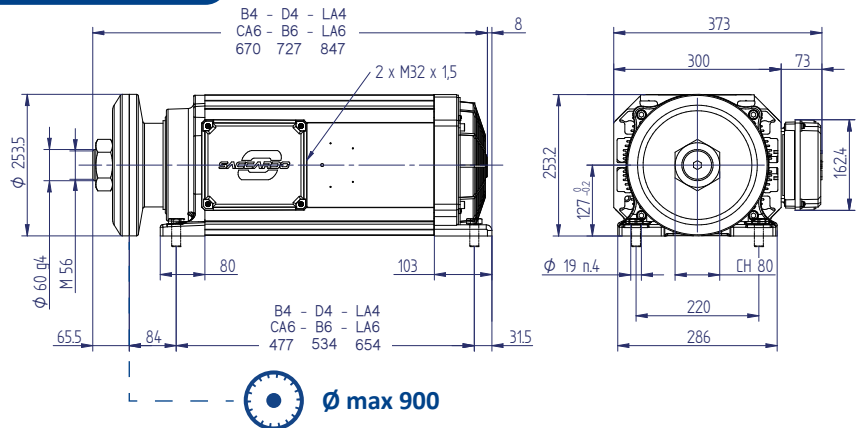

Servoventilato 24 Volt DC
 Servo-fan 24 Volt DC

Rumorosità < 80dB
 Noise < 80dB

4 POLES / 400V

Size	Duty	50 Hz				Kg
		kW	Nm	rpm	A	
B4	S1	22	145	1450	42	134
	S6-60%	25,3	173	1435	51	
D4	S1	27	178	1450	52	148
	S6-60%	33,2	219	1435	64	
LA4	S1	33	217	1455	63	169
	S6-60%	40	265	1440	75	

Max vel. 3800 rpm (127 Hz)
 Max speed 3800 rpm (127 Hz)

6 POLES / 400V

Size	Duty	50 Hz				Kg
		kW	Nm	rpm	A	
CA6	S1	17	171	950	34,3	123
	S6-60%	20,4	208	935	44,8	
B6	S1	21	210	955	46,7	143
	S6-60%	25,1	255	940	54,3	
LA6	S1	28	280	955	61,8	169
	S6-60%	33,3	338	940	71,2	

Max vel. 3800 rpm (190 Hz)
 Max speed 3800 rpm (190 Hz)

SBE.L 127

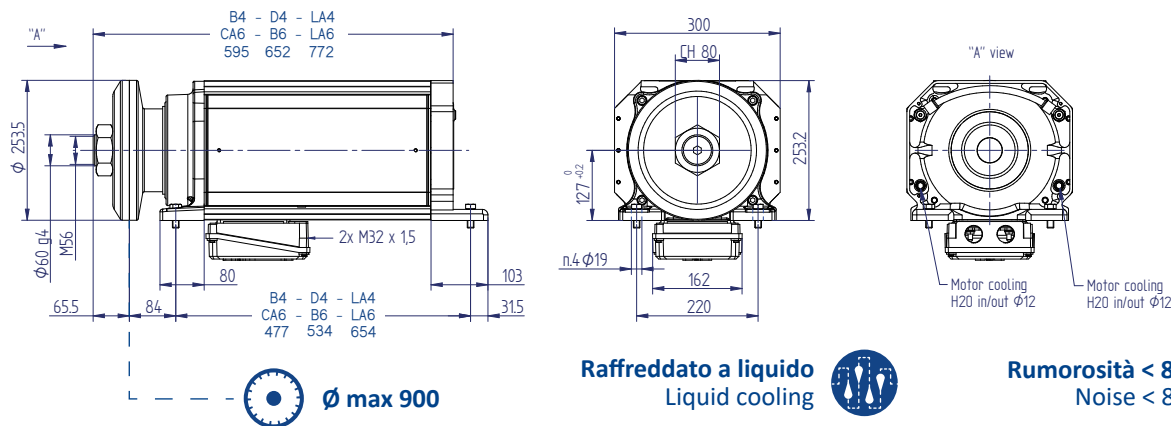

4 POLES / 400V

Size	Duty	50 Hz				Kg
		kW	Nm	rpm	A	
B4	S1	27	179	1440	56,5	135
	S6-60%	33,2	223	1420	69,1	
D4	S1	33	219	1440	67,7	149
	S6-60%	40	269	1420	82,7	
LA4	S1	42	277	1445	82,7	170
	S6-60%	50	334	1430	98,5	

Max vel. 3800 rpm (127 Hz)
 Max speed 3800 rpm (127 Hz)

6 POLES / 400V

Size	Duty	50 Hz				Kg
		kW	Nm	rpm	A	
CA6	S1	20	204	935	41	124
	S6-60%	24	250	915	49,3	
B6	S1	25,6	260	940	53	144
	S6-60%	31	320	925	63,2	
LA6	S1	33,3	338	940	67,6	170
	S6-60%	40	413	925	80	

Max vel. 3800 rpm (190 Hz)
 Max speed 3800 rpm (190 Hz)

Flangia Rasata / Flat Flange



Gli SBE a Flangia Rasata sono elettromandrini da taglio a basso ingombro assiale. Il disco da taglio viene fissato senza controflangia e dado, riducendo lo spazio frontale necessario alla lavorazione. Potenze e dimensioni sono uguali alla serie SBE.

SBE with flat flange are electrospindles for cutting processes with low axial dimensions. The cutting disc is fixed without counterflange and locking nut, reducing the frontal space necessary for processing. Powers and dimensions are the same as the SBE series.

SBE.FR 93

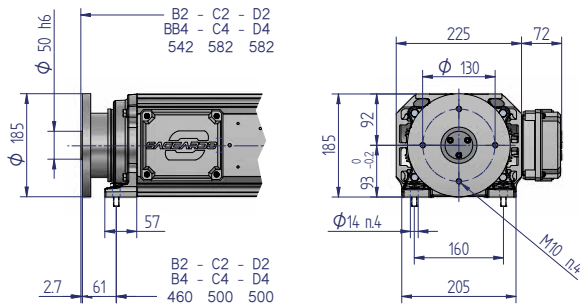

SBE.FR 107

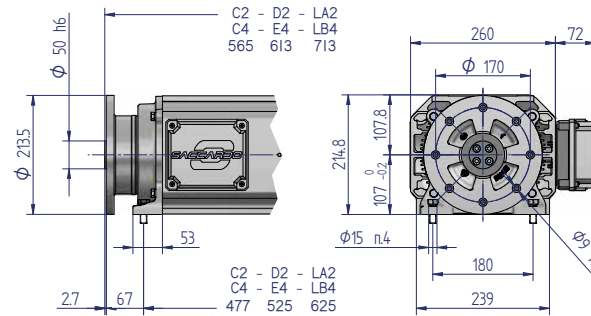

SBE.FR 127

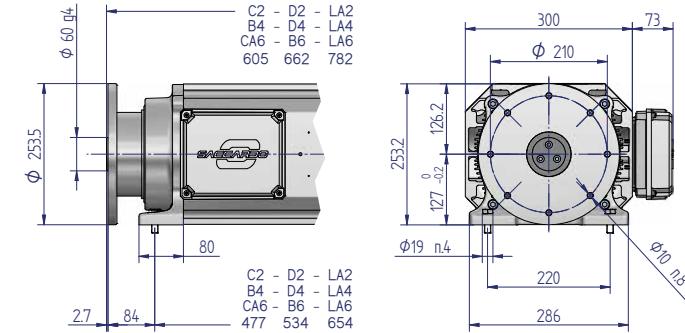

Some custom solutions

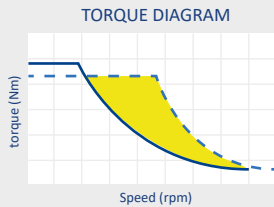

Potenze e coppie
Power and torques

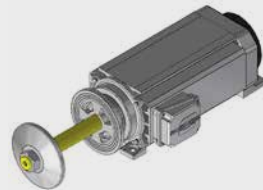

Alberi allungati
Elongated shafts

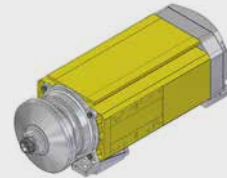

Carcassa lavorata
Machined motor frame

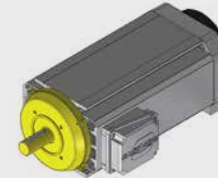

Attacco flangiato
Front flanged fixing



Dado antisvitamento
Self-locking nut



Flange e portautensili
Flanges and toolholders

Le caratteristiche dei prodotti inseriti nel presente catalogo sono indicative. Saccardo GCF S.r.l.u. si riserva di apportare, senza preavviso, modifiche ai componenti ove ritenuto necessario al fine di migliorare la qualità del prodotto in base alle conoscenze tecniche acquisite e all'attuale stato dell'arte.

The product features described in the present catalogue are approximated. Saccardo GCF S.r.l.u. reserves the right to make any modification to the components whenever deemed necessary, without prior notice, in order to enhance the product quality, based on the technical knowledge acquired and the current state of the art.

Saccardo GCF S.r.l.u.
Via Lago di Costanza, 67/69
36015 Schio (VI) - Italy

